

Clavicula M³/SE

*Road
MTB*

Road



Instruction book

THM Clavicula M³_SE_1_en, 2015-06



Don't forget that your THM component is a lightweight carbon design. Be aware of this when carrying out assembly and maintenance work and when handling the component. Proceed with utmost care!

Instruction book

INTRODUCTION

Preface	5
----------------------	---

SAFETY

Intended use	6
Fundamental safety precautions	6
Assembly & maintenance	6
On the road	7
Transport & storage	7

SPECIFICATIONS

Scope of delivery	8
Bottom bracket	9
Size	10
Tightening torques	11
Application area	11

ASSEMBLY

Installing the Clavicula	12
Preparing the frame	12
Spacers	13
Installing the bottom bracket	14
BSA/ITA	14
BB30/PressFit 30/BBright™ PressFit	15
Press-fit/EVO386	16
BBright™ Direct Fit	16
Installing the spider	16
Assembling the chainwheels	18
Installing the cranks	18
Adjusting the bottom bracket	20
Assembling the pedals	21
Finishing touches	21

MAINTENANCE

Important maintenance information	22
Disposal	23
Before each trip	24
Checking the bottom bracket clearance	24
Regular maintenance	25
Dismantling the bottom bracket	26

LEGAL

Liability for defects	28
Fair deal promise	28
Crash Replacement	28

Preface



This manual is an integral part of your THM component and it provides you with information regarding the safe operation of your THM-Clavicula crank system.

Read this manual carefully prior to assembling your THM component. Always read and observe all of the assembly and maintenance instructions in this manual, as well as those provided in the manuals of other manufacturers whose products are used on your bicycle (e.g. frame, chainwheels, pedals, etc.).

WARNING

Non-observance of the information contained in this manual could result in an accident and death or serious injury.

You will encounter the following symbols and references in this manual:

-  The index finger instructs you to perform a particular action.
-  The arrow indicates the consequence of your action.

WARNING

This safety message indicates a hazardous situation which, if not avoided, could result in death or serious injury.

CAUTION

This safety message indicates a hazardous situation which, if not avoided, could result in minor or moderate injury.

NOTICE

This message warns of a risk of material damage.



This refers to additional information or tips.

Retain this manual for other users of your THM components.

Make sure that all users read, understand and observe this manual.

If you ever sell or give away your THM components, this manual should be transferred to the new owner.

We hope you get a lot of joy from your THM components!

Your THM-Carbones Team

Intended use

⚠ WARNING

Any use other than that intended can cause accidents resulting in death or serious injury.

THM-Clavicula crank systems have been exclusively designed

- for installation on standard racing cycles, time trial and mountain bikes.
- for the permitted area of application – see **Application area**, page 11.

Fundamental safety precautions

The following warnings for the THM-Clavicula component apply to all Clavicula models (Clavicula Road, Clavicula MTB etc.), unless otherwise specified.

For the time being we limit the service life of your THM-Clavicula crank system to 100,000 km or 10 years. It is imperative you contact us before continuing to use your THM-Clavicula crank system after one of these limits has expired!

Always remember that riding a bicycle involves potential danger for the rider and other road users, as well as for the bicycle and its components. Even if protective equipment and safety devices are used, accidents resulting in death or serious injury can still occur.

You should also rely on your common sense and avoid any unreasonable behaviour!

Assembly & maintenance

⚠ WARNING

Risk of accident caused by assembly and maintenance work which has not been conducted in a professional manner.

- Do not overestimate your technical ability. All assembly and maintenance work should be performed by a specialist workshop for bicycles. This is the only way to ensure that work is conducted in a professional manner.
- Always observe all of the specified tightening torques for the screw connections.
- Only use suitable, undamaged, high-quality tools.
- Only ever use original THM components which are available from your specialist dealer or directly from THM.
- Never make any modifications to your THM components.
- Check your crank system (incl. cranks, bottom bracket, chainwheels) to make sure it is undamaged and functioning properly before every ride. Send us your THM-Clavicula component before further use if damage is visible (cracks, fractures, deformations, etc.) or if you are in any doubt about its functionality.
- Check your THM components before each journey to ensure the surfaces are completely undamaged. Send us your THM components for inspection before further use if damage is visible (deep scratches in the paintwork which extend into the carbon structure, large abrasions, etc.), if you are in any doubt about their functionality or if the Clavicula lettering is abraded at one or more points (wear indicator).
- Always ensure your bicycle is maintained in a flawless condition. Care and maintenance will prolong the service life of your bicycle and its components and also improve your personal safety.

On the road

WARNING

Danger of accidents due to improper behaviour or improper equipment during riding.

- Always ride with foresight, attention and a readiness to brake.
- Adjust your speed to the prevailing conditions (traffic, weather, visibility, etc.).
- Do not use your THM components at ambient temperatures below -10°C (14°F).
- Do not exceed the maximum overall weight for which your THM components have been approved – see **Size**, page 10.
- Do not perform jumps with your bicycle as this generates an enormous amount of force.
- Always comply with the traffic regulations that are in force in the country where you are using your bicycle.
- When riding your bicycle you should always wear a high quality cycling helmet (e.g. ANSI certified) that is in excellent condition. Your clothing should be close-fitting but not restrictive.
- Only ride your bicycle if you are in good physical condition and your bicycle and all of its components are in perfect working order.
- If you are involved in a heavy fall you should not continue riding your bicycle. If such a case occurs, send us your THM components for inspection, even if no external damage is visible! In your own interest you should treat all components on your bicycle which are produced by other manufacturers in the same way.

When riding your mountain bike, also comply with the directives of the International Mountain Bike Association (IMBA):

- Only use permitted routes.
- Avoid leaving tracks.
- Always keep your bicycle under control.
- Ride in a manner that is suitable for the terrain.
- Do not startle any animals.
- Always ride in an anticipatory manner.
- Be prepared for any eventuality.

For more information please visit www.imba.com .

Transport & storage

WARNING

Risk of accident caused by damaged bicycle components.

- Always transport your bicycle in an appropriate and careful manner.
- Do not store your THM components at an ambient temperature below -15°C (5°F) or above 55°C (131°F).

Risk of accident.

- Do not allow children to play with your bicycle.

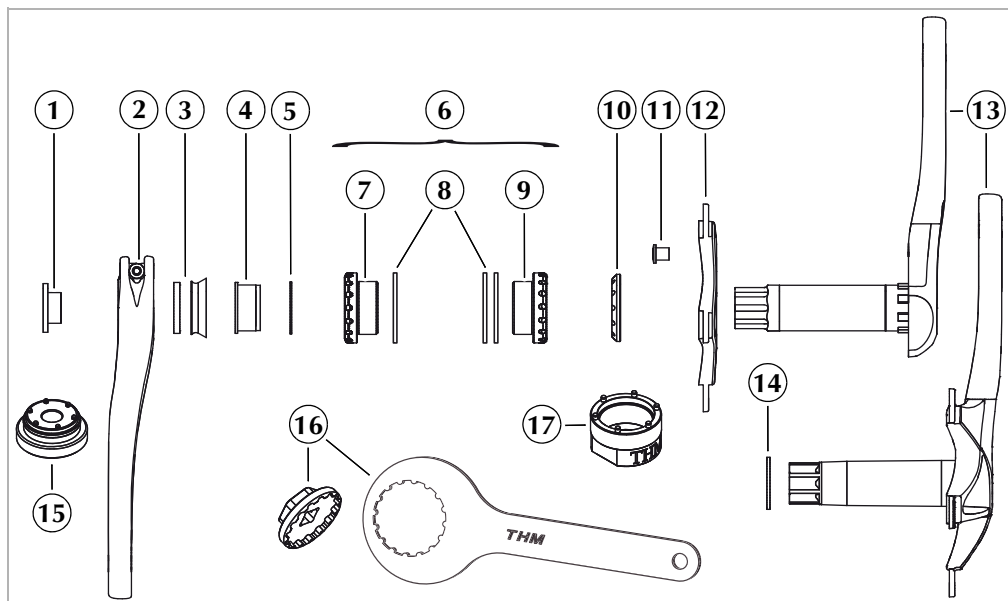

Scope of delivery

- (1) Adjusting screw
- (2) Crank, left
- (3) Spacer ring, 1× 2.5 mm (M³Road)/9,7 mm (M³MTB)
- (4) Cone sleeve (SE Road)
- (5) Spacer ring, 1× 1.0 mm (SE Road)
- (10) Lockring for spider (M³ MTB)
- (11) Hollow screw for spider (M³Road),
5× M8×0.75 × 10 mm
- (12) Spider* (optional)
- (13) Axle crank
- (14) Spacer ring, 1× 2.0 mm (SE Road)
- (17) THM locking tool (M³ MTB)

Instruction book

Not included in delivery:

- (6) Bottom bracket (opt.) – see **Bottom bracket**, page 9
- (7) Bearing cup, left (marked by groove)
- (8) Spacer, 2.5 mm
- (9) Bearing cup, right
- (15) THM adjusting tool
- (16) THM bottom bracket tool (optional)

These items must be ordered separately if necessary.

* without chainwheels and chainwheel bolts

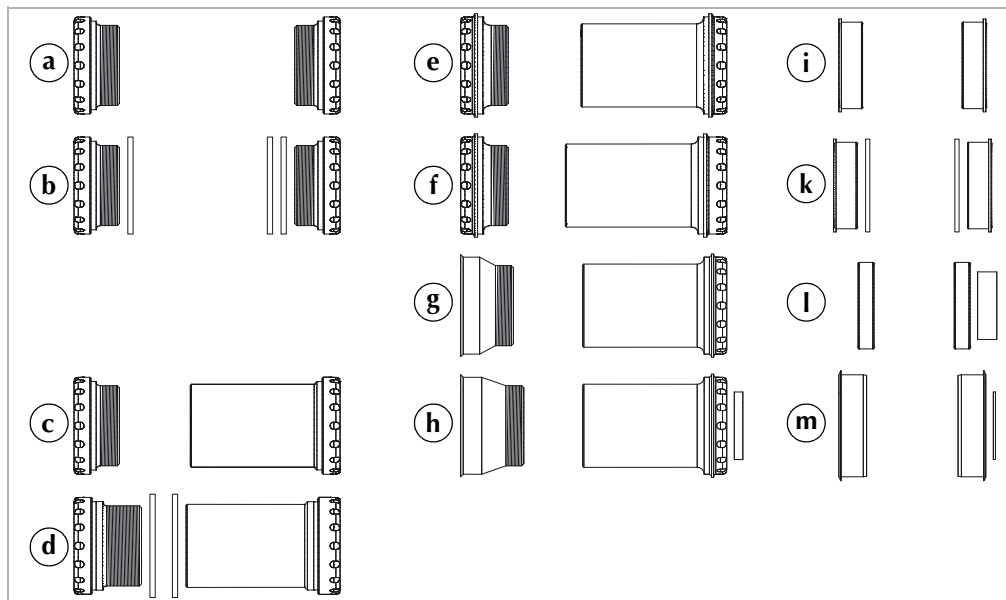

Bottom bracket

- (a) **Road** (BSA/ITA): Bearing cup left/right
- (b) **MTB** (BSA): Bearing cup left/right, 3× spacer ring (2.5mm)
- (c) **BB30 Road**: Bearing cup left/right
- (d) **BB30 MTB**: Bearing cup left/right, 2× spacer ring (2.5mm)
- (e) **PressFit 30 Road**: Bearing cup left/right
- (f) **PressFit 30 MTB**: Bearing cup left/right
- (g) **BBright™ PressFit Road**: Bearing cup left/right
- (h) **BBright™ PressFit MTB**: Bearing cup left/right, 1× spacer ring, right (4.0mm)
- (i) **Press-fit Road**: Bearing cup left/right
- (k) **Press-fit MTB**: Bearing cup left/right, 2× spacers (2.0mm)
- (l) **BBright™ Direct Fit Road**: 2× bearings, 1× spacer ring, right (9.5mm)
- (m) **EVO386 Road (FSA®)**: Bearing cup left/right, 1× spacer ring, right (1.0mm)

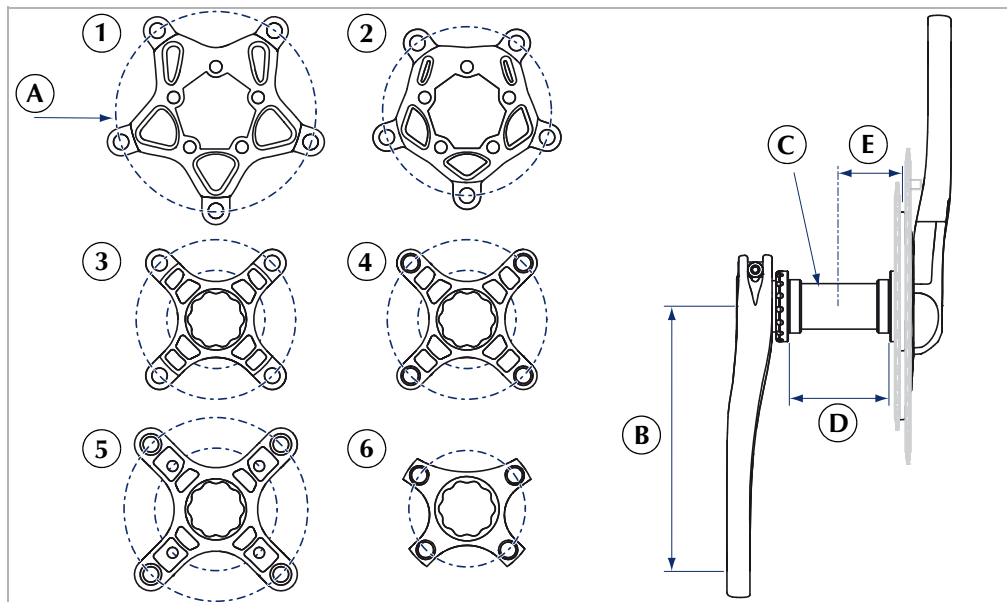

Size

		Road		MTB		
		Compact	3-104/64	2-104/64	2-120/80	XX1-76
	(1)	(2)	(3)	(4)	(5)	(6)
(A)	Ø bolt circle	130	110	104/64	120/80	76
	Teeth, min.	39	34	32/21	37/25	26
(B)	Crank length	170.0/172.5/175.0				
(C)	Ø axle	30				
(D)	BSA (ITA)**	mm	68,0 (70,0) ±0,2		68,0/73,0 ±0,2	
	BB30		68,0 ±0,2 (Ø 42,0)		68,0/73,0 ±0,2 (Ø 42,0)	
	PressFit 30 (SRAM®)		68,0 ±0,2 (Ø 46,0)		73,0 ±0,2 (Ø 46,0)	
	BBright™ PressFit		79,0 ±0,2 (Ø 46,0)		84,0 ±0,2 (Ø 46,0)	
	Press-fit (Shimano®)		86,5 ±0,2 (Ø 41,0)		89,5/92,0 ±0,2 (Ø 41,0)	
	BBright™ Direct Fit		79,0 ±0,2 (Ø 42,0)		-	
	EVO386 (FSA®)	86,5 ±0,2 (Ø 46,0)		-		
(E)	Chain line (ITA)	43.5 (44.5)	50.0	49.5	47.0/49.0	
	Total weight, max.***	kg(lb)	110 (243)	120 (265)		

* Technical specifications, dimensions and weights are to be understood with the corresponding tolerances and can differ slightly from your THM components.

** BSA (1.37"×24 tpi) / ITA (36×24 tpi)

*** Total weight = rider + bicycle + luggage

Tightening torques

⚠ WARNING

Risk of accident caused by a malfunctioning crank system due to loose screw connections.
-Check the required tightening torque of all screw connections after the first 100 km - retighten the connections if necessary. Repeat this check every 2500km!

	N·m (lbf·in) max.	
Bearing cups	40 (354)	greased
Adjusting screw	10 (89)	with thread lock
Crank clamping bolt	10 (89)	
Hollow screw for spider	6 (53)	
Lockring spider	30 (266)	
Chainwheel bolts, aluminium	6 (53)	greased
Chainwheel bolts, steel	12 (106)	
Pedal threads	20 (177)	

Application area

⚠ WARNING

Risk of accident caused by a malfunctioning crank system due to overload.
-Only ever use your Clavicula component within its permitted area of application.

Clavicula M ³ /SE Road	X1–X2
Clavicula M ³ MTB	X1–X3

- X1** Racing cycle and light cross-country terrain
- X2** Touring, road
- X3** medium/heavy terrain
- X4** Free ride, heavy terrain
- X5** Downhill, extreme terrain

Installing the Clavícula

⚠ WARNING

If not properly performed, assembly and maintenance work can cause accidents resulting in serious or fatal injury.

-Do not overestimate your technical ability. All assembly and maintenance work should be performed by a specialist workshop for bicycles. This is the only way to ensure that work is conducted in a professional manner.

Preparing the frame



It is imperative you read and observe the safety and assembly information provided by the manufacturer of your frame.

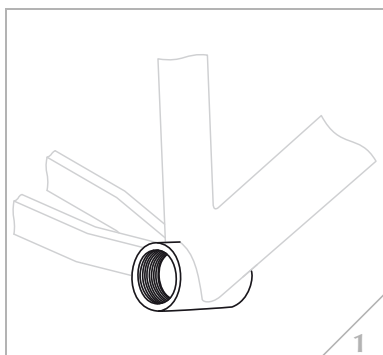

- ☞ Secure your bicycle in an appropriate assembly stand.
- ☞ If necessary remove the crankset and the old bottom bracket.
- ☞ If necessary, use cleaning solvent or other similar agents to clean the bottom bracket housing of your frame.
- ☞ Make sure that the edges of the bottom bracket housing are plane, parallel, milled to the correct dimensions and free of burrs – see **Size**, page 10. If necessary, rework the bottom bracket housing using an appropriate milling tool (Cyclus, ParkTool or other similar tool).
- ☞ Make sure that the threads of the bottom bracket housing are clean, free from paint residues and adequately tapped into the housing. If necessary, rework the threads with an appropriate cutting tool (Cyclus, ParkTool or other similar tool).

(fig. 1)

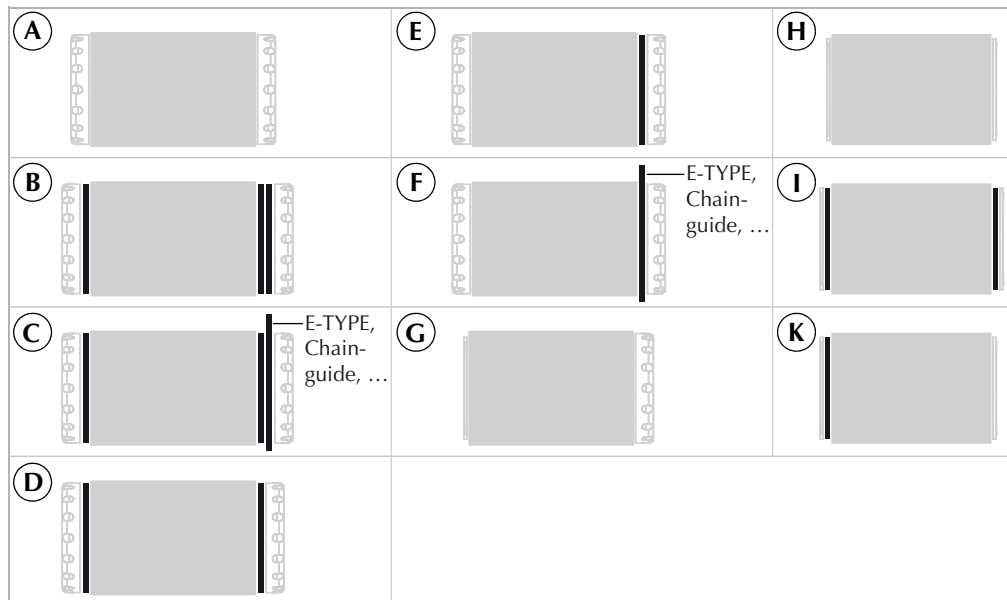

Spacers

Bottom bracket housing	Bottom bracket	Front derailleur type	Spacers		Fig.
			Anticlockwise	Clockwise	
68.0 mm (70.0 mm)	Road BSA (ITA); BB30 Road; PressFit 30 Road	Clip-on/ braze-on	0	0	(A)
	MTB BSA	E-TYPE	1 × 2.5 mm	2 × 2.5 mm	(B)
				1 × 2.5 mm + E-TYPE	(C)
		Clamp		1 × 2.5 mm	(D)
73.0 mm	BB30 MTB; PressFit 30 MTB	Clamp	0	0	(A)
	MTB BSA	E-TYPE		1 × 2.5 mm	(E)
				0 + E-TYPE	(F)
79.0 mm	BBright™ PressFit Road	Clip-on/ braze-on	0	0	(G)
	BBright™ Direct Fit Road				-
84.0 mm	BBright™ PressFit MTB	Clamp	0	0	(G)
86.5 mm	Press-fit Road; Evo386 Road	Clip-on/ braze-on	0	0	(H)
89.5 mm	Press-fit MTB sym.	Clamp	1 × 2.0 mm	1 × 2.0 mm	(I)
92.0 mm	Press-fit MTB asym.	Clamp	1 × 2.0 mm	0	(K)

Installing the bottom bracket



Do not use the **Clavicula Road** in combination with an E-TYPE front derailleur!

The THM socket wrench (1)(fig. 3), which can be used as a torque wrench, can be obtained from us or from your specialised dealer.

- ☞ Measure the width of the bottom bracket housing of your bicycle frame.
- ☞ Identify the type of front derailleur used on your bicycle.
- ☞ Use the table to determine the correct number of spacers for both sides of the bottom bracket – see **Spacers**, page 13.
- ☞ Make sure that the securing bolt of the derailleur cable guide does not protrude into the bottom bracket housing by more than 1 mm.
- ☞ Apply grease to the threads and contact surfaces of the bearing cups.

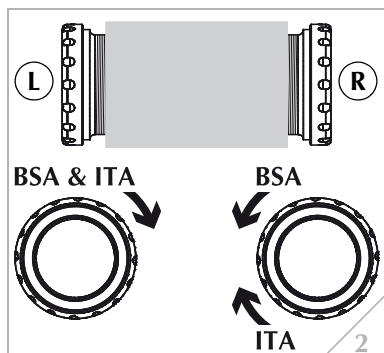

BSA/ITA

- ☞ Fit the correct number of spacers to the right-hand bearing cup (R).
- ☞ Screw the right-hand bearing cup (R) – initially by hand – into the right-hand side of the bottom bracket housing using an **anti-clockwise (BSA)** or **clockwise (ITA)** motion.
- ☞ Fit the correct number of spacers to the left-hand bearing cup (L) (marked by groove).
- ☞ Screw the left-hand bearing cup (L) – initially by hand – into the left-hand side of the bottom bracket housing using a **clockwise motion (BSA & ITA)**.

(fig. 2)

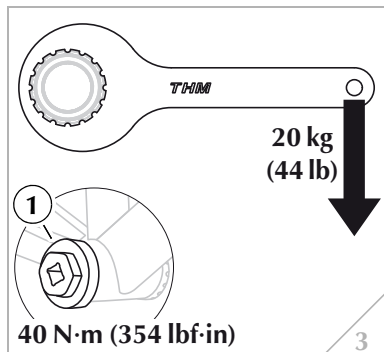

- ☞ Tighten both bearing cups using a tightening torque of **40 N·m (354 lbf-in)**.

➔ This torque corresponds to a manual force of approx. 20 kg (44 lb) at the end of the THM bottom bracket tool. (fig. 3)

BB30/PressFit 30/BBright™ PressFit

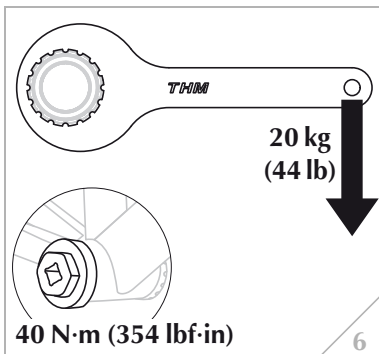
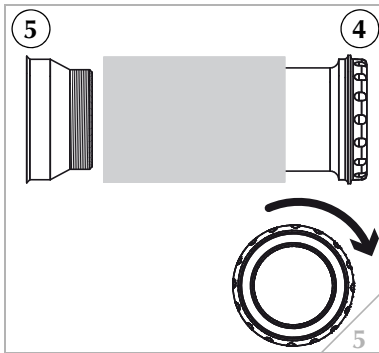
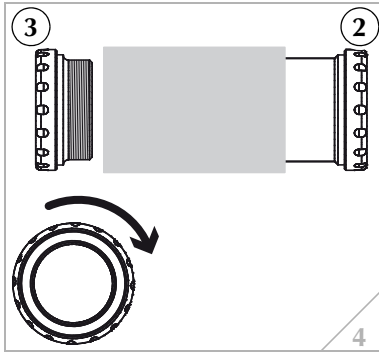

i

When dealing with BB30, PressFit 30 and BBright™ PressFit bottom brackets, the bearing cup with internal thread (2) or (4) is always located to the right, while the bearing cup with external thread (3) or (5) is always located to the left.

– see **Bottom bracket**, page 9.

- ☞ Fit the correct number of spacers to the bearing cup (2).
- ☞ Insert the bearing cup (2) or (4) by hand as far as possible into the right-hand side of the bottom bracket housing.
- ☞ Fit the correct number of spacers to the bearing cup (3).
- ☞ Screw the bearing cup (3) or (5) by hand as far as possible into the right-hand bearing cup using a **clockwise** rotation.
- ☞ Make sure that both bearing cups are located centrally in front of the bottom bracket housing. (fig. 4, 5)
- ☞ Tighten the bearing cup (3) or (4) using a tightening torque of **40 N·m (354 lbf·in)**.
- ➔ This torque corresponds to a manual force of approx. 20 kg (44 lb) at the end of the THM bottom bracket tool.

(fig. 6)

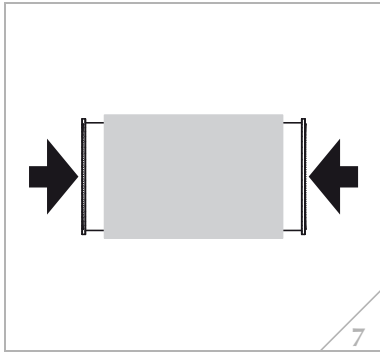

Press-fit/EVO386

- ☞ Fit the correct number of spacers to the bearing cups – see **Spacers**, page 13.
- ☞ Press both bearing cups simultaneously into the bottom bracket housing as far as possible by using a suitable pressing tool (e.g. Park Tool®).

(fig. 7)

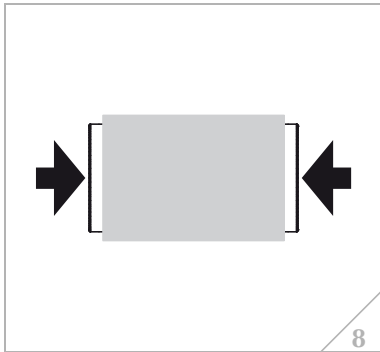

BBright™ Direct Fit

- ☞ Press both bearings simultaneously into the bottom bracket housing as far as the housing stop by using a suitable pressing tool (e.g. Park Tool®).

(fig. 8)

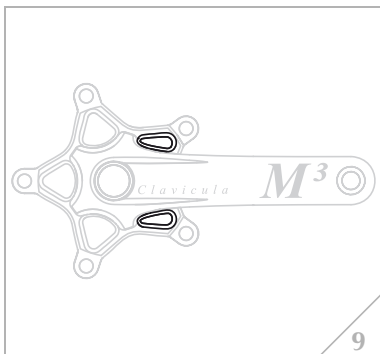

Installing the spider

Road



The spider is positioned correctly when the two small contoured sections on the outer side are located next to the arm of the axle crank.

(fig. 9)

⚠ WARNING

Risk of accident caused by a malfunctioning spider due to the use of hollow screws that are too long or too short.

-Only ever use original THM hollow screws when attaching the spider.

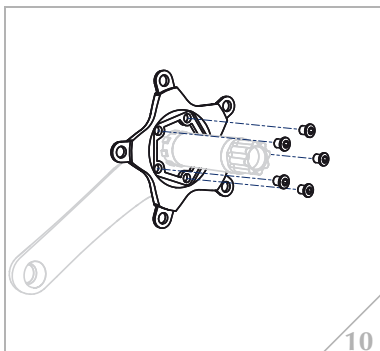

- ☞ Make sure that the hollow screw threads are provided with fresh, medium-strength thread lock.
- ☞ Always tighten the hollow screws in a crosswise manner using a tightening torque of **6 N·m (53 lbf·in)**.

(fig. 10)

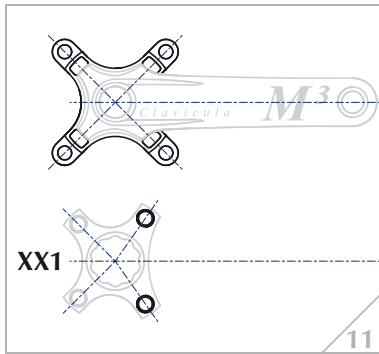

MTB



The spider is positioned correctly when the mounts for the chainwheel bolts are located symmetrically to the arm of the axle crank.

When using the XX1 spider both of the mounts of the chainwheel bolts must point in the direction of the pedal eye. (fig. 11)

⚠ WARNING

Risk of accident caused by a malfunctioning spider due to an unsuitable locking.

-Only ever use the original THM locking when attaching the spider.

- ☞ Make sure the thread of the locking is provided with fresh, medium-strength thread lock.
- ☞ Use the THM locking tool to tighten the locking with a tightening torque of **30N·m (266lbf·in)**. (fig. 12)

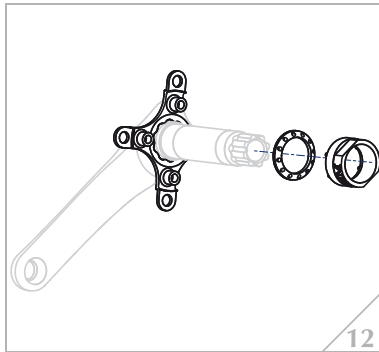

SRM PowerMeter



If you have an SRM PowerMeter that you would like to use, please contact SRM directly to inquire whether it is compatible with your Clavicula M³.

Always observe the installation instructions provided by SRM. Tighten the mounting screws (Road) or locking (MTB) of the SRM PowerMeter by using the specified tightening torque; when doing this make sure you do not exceed a tightening torque of max. **6N·m (53lbf·in)** (screws, Road (fig. 13)) or max. **30N·m (266lbf·in)** (locking, MTB (fig. 14)) under any circumstances.

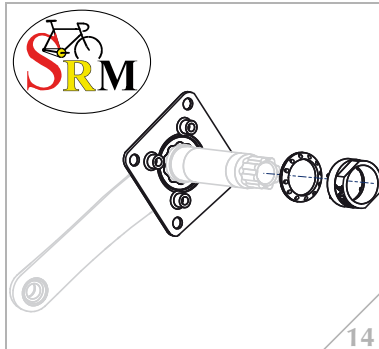
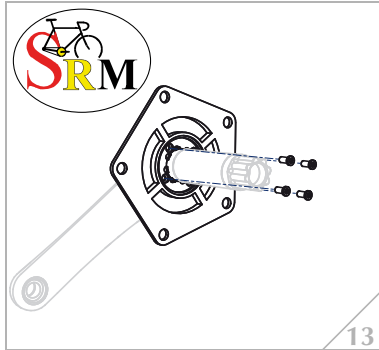

Assembling the chainwheels

NOTICE

Danger of damage to the chainwheel mount or axle crank.

- The number of chainwheel teeth must never be below the minimum number required – see **Size**, page 10.
- Always mount 2 chainwheels on the outer chainwheel mount for the corresponding spiders (Road, Road Compact, MTB 3-104/64) (fig. 15).
- Always observe the tightening torques specified by the manufacturer of the chain ring bolts; however, do not exceed a max. tightening torque of **12N·m (106lbf·in)** under any circumstances.

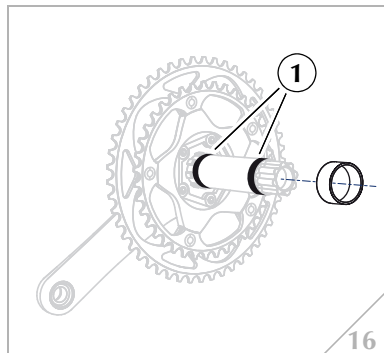
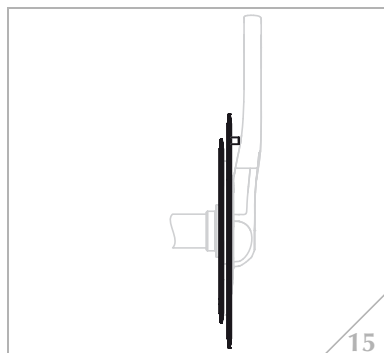

Installing the cranks

- ☞ **M³**: Insert the corresponding spacer ring onto the axle - only when using the following bottom brackets: BBright™ Direct Fit Road: 9.5mm. BBright™ PressFit MTB: 4.0mm. EVO386 Road: 1.0mm.
- ✂ **SE**: Insert the 2.0mm spacer ring onto the axle (ITA and BBright™ PressFit Road 1.0mm !). Additionally for the following bottom bracket: BBright™ Direct Fit Road: 9.5 mm.
- ☞ Lightly grease the bearing seat(1) of the axle. (fig. 16)

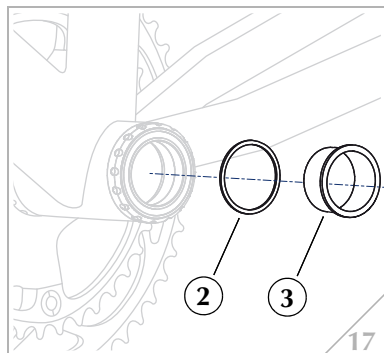

- ✂ **SE**: Locate the 1.0 mm spacer ring (2) on the cone sleeve (3) (not ITA ! BBright™ PressFit Road 2.0mm !).
- ✂ **SE**: Insert the cone sleeve into the left bearing on the bottom bracket up to the stop. (fig. 17)

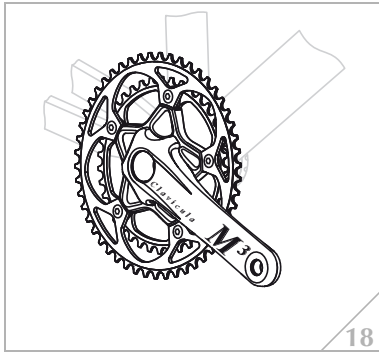

- ☞ Insert the axle crank through the bottom bracket up to its stop. (fig. 18)

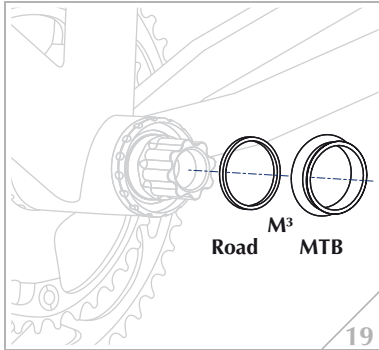

- ☞ Thoroughly degrease the axle and crank multi-tooth segment.
- ✂ **M³**: Insert the spacer ring onto the axle.
 - Road: 2.5 mm
 - MTB: 9.7 mm
 - Additionally for the following bottom bracket: BBright™ PressFit: 1.0 mm.

(fig. 19)

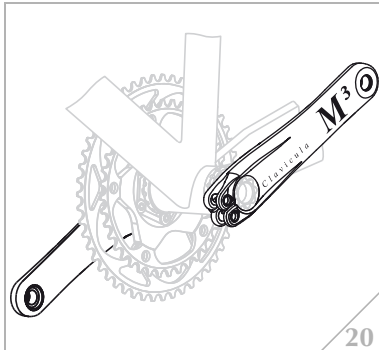

- ☞ Fit the left-hand crank to the multi-tooth segment of the axle.
- ☞ Make sure the left and right-hand crank are seated correctly!
- ☞ Press the cranks together by hand up to the limit stop.
- ➔ Both cranks abut against the inner rings of the bearings.
- ☞ Check the clearance between the cranks and the chainstays of the frame.
- ➔ Minimum crank to chainstay clearance: 3 mm

(fig. 20)

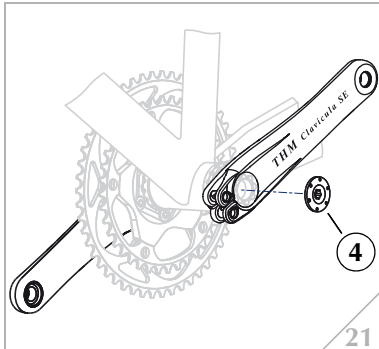

- ✂ **SE**: Screw the adjusting screw (4) into the axle – use the THM adjustment tool, or an 8mm Allen key for this.
- ✂ **SE**: Tighten the adjusting screw until the collar on the cone sleeve is flush against the bearing or spacer ring. The tightening torque required for this is typically **5–12 N·m (44–106 lbf·in)** – depending on the actual width of the bottom bracket housing.
- ✂ **SE**: Remove the adjusting screw.
- ✂ **SE**: Slightly loosen the left crank.

(fig. 21)

Adjusting the bottom bracket

NOTICE

Accelerated bearing wear if the bottom bracket is set too rigidly due to excessive pre-tensioning of the adjusting screw.

-Only adjust the bottom bracket if the clamping screw (1) has been loosened!

As a rule, the required tightening torque of the adjusting screw (2) for a correctly adjusted bottom bracket is approximately **0.3–1 N·m (3–9 lbf-in)**.

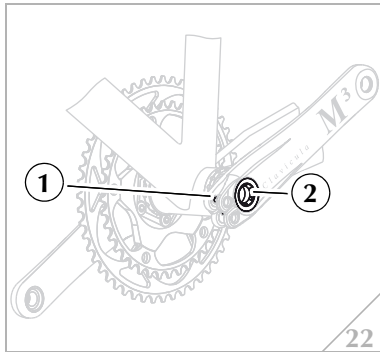

- ☞ Apply a medium-strength thread lock (Loctite or other similar) to the thread of the adjusting screw.
- ✂ Screw the adjusting screw into the axle – when doing this use the THM adjusting tool, the end of the THM bottom bracket tool, a suitable coin (such as a 1 Euro piece), or an 8mm Allen key (SE).
- ☞ Tighten the adjusting screw carefully and slowly until the bottom bracket does not exhibit any play, but can still be turned easily by hand.
- ➔ Adjustment of the bottom bracket is now complete. (fig. 22)

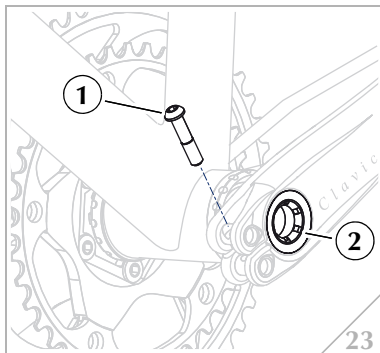

- ☞ Remove the clamping screw (1).
- ☞ Apply a medium-strength thread lock (Loctite or other similar substance) to the thread of the clamping screw.
- ☞ Replace the clamping screw.
- ☞ Tighten the clamping screw using a tightening torque of **10 N·m (89 lbf-in)**.
- ☞ Tighten the adjusting screw (2) using a tightening torque of **10 N·m (89 lbf-in)** to prevent it from becoming lost during travel. (fig. 23)

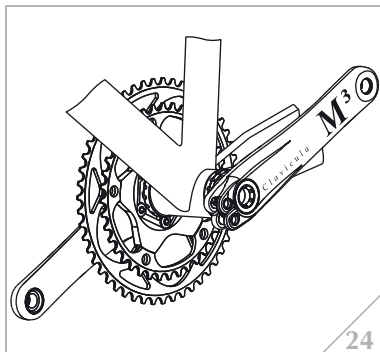

- ➔ Installation of your Clavicula component is now complete. (fig. 24)

⚠ WARNING

Risk of accident caused by a malfunctioning crank system due to loose screw connections.

-Allow the thread lock to harden in line with the manufacturer's specifications before using your Clavicula component.

Assembling the pedals

NOTICE

Danger of damage to the carbon structure around the pedal threads.

- It is essential you do not confuse the RH and LH pedal!
- Do not exceed the maximum tightening torque for the pedals prescribed by THM – max. **20N·m (177lbf-in)**!



Right-hand pedal: Right-hand thread

Left-hand pedal: Left-hand thread

- ☞ Apply grease to the threads of the pedals.
- ☞ Assemble your pedals.

Finishing touches

⚠ WARNING

Risk of accident caused by a malfunctioning crank system due to loose screw connections.

- Check the required tightening torque of all screw connections after the first 100 km – re-tighten the connections if necessary. Repeat this check every 2500km! Apply fresh thread lock if necessary.

Risk of accident caused by a malfunctioning crank due to wear.

- Do not continue to use your Clavicula component if the Clavicula lettering is abraded at one or more points (wear indicator).



Please note that if you use overshoes, or if there is an extremely small clearance between the brake shoe and crank, it will cause the crank surface to wear. This level of wear is increased significantly if the bike is used frequently in wet and dirty conditions!

You can counteract this wear by sticking an appropriate protective film (Lizard Skins or other similar film) over the areas that are susceptible to wear.

Check these areas for wear at regular intervals!

- ☞ Check the position and adjustment of the front derailleur as well as the chain line. Readjust the front derailleur if required.

Important maintenance information

⚠ WARNING

If not properly performed, assembly and maintenance work could cause accidents resulting in death or serious injury.

- Do not overestimate your technical ability. All assembly and maintenance work should be performed by a specialist workshop for bicycles. This is the only way to ensure the work is conducted in a professional manner.

Improperly performed assembly and maintenance work could also result in a loss of your warranty rights (liability for defects)!

⚠ WARNING

Risk of accident caused by damaged components.

- Never attempt to disassemble your THM-Clavicula component - only THM employees are authorised to do this.

- Always read and observe all of the assembly and maintenance instructions in this manual, as well as those provided in the manuals of other manufacturers whose products are used on your bicycle (e.g. frame, chainwheels, pedals, etc.).

- Always observe the minimum and maximum values specified – see **Specifications**, from page 8.

- Only use suitable, undamaged, high-quality tools.

- When conducting assembly steps that require a specific tightening torque, always use an appropriate torque wrench that is designed for the tightening torque specified.

NOTICE

Never use a high-pressure cleaner or steam cleaner to clean your bicycle, as the seals of your bicycle components are not able to withstand the pressure. If such cleaners are used, it would result in corrosion and material damage.

Never use caustic solvents (such as paint thinners, acetone, nitro compounds, etc.) as they can attack the surface of your THM components.

Only use commercially available paint care products and water to clean your THM components. Spirit or petrol should be used carefully

- when using such products avoid excessive wiping and prolonged exposure times.

Always ensure your bicycle is maintained in a flawless condition. Care and maintenance will prolong the service life of your bicycle and its components and improve your personal safety!

If you suspect that your bicycle is defective or is not functioning properly, stop using it and contact a specialist bicycle workshop immediately!

Disposal

If THM components are defective or no longer in use, you can dispose of them with your non-recyclable waste or domestic refuse, or ask a local waste disposal company for other disposal methods (e.g. recycling).

Before each trip

⚠ WARNING

Risk of accident due to material damage or assembly error.

- Check your THM components before each journey to ensure the bonded joints are completely undamaged. Send us your THM components for inspection before further use if damage is visible (cracks, fractures, clicking sounds, wobbling, etc.) or if you are in any doubt about their functionality.
- Check your THM components before each journey to ensure the surfaces are completely undamaged. Send us your THM components for inspection before further use if damage is visible (deep scratches in the paintwork which extend into the carbon structure, large abrasions, etc.), if you are in any doubt about their functionality or if the Clavicula lettering is abraded at one or more points (wear indicator).
- Do not exceed the maximum overall weight for which your THM components have been approved – see **Size**, page 10.

Checking the bottom bracket clearance

NOTICE

Risk of damage to the bearings.

- Never try to remove the bearing seals from the bottom bracket.
- Your THM bottom bracket is elaborately sealed and provided with permanent lubrication. There is no need to re-lubricate the bearings!

- ☞ Grasp both cranks of your bicycle.
- ☞ Try to move the cranks to the left and right.
 - ➔ If you feel bearing play, it means that the bottom bracket is loose and needs to be adjusted immediately – see **Adjusting the bottom bracket**, page 20.
- ☞ Now shift the chain onto the smallest chainwheel.
- ☞ Remove the chain from the chain ring and place it onto the bottom bracket housing.
 - ➔ The bottom bracket can now be rotated freely.
 - ☞ Use two fingers to grasp one of the cranks directly by the bottom bracket axle and rotate the axle in its bearing.
 - ➔ If the bottom bracket axle rotates with perceptible resistance, it means that the bottom bracket is too tight and must be adjusted immediately – see **Adjusting the bottom bracket**, page 20.

Regular maintenance

The maintenance intervals required for your bicycle depend on how often and in which weather conditions it is used.

The following maintenance measures should be conducted more frequently if the bicycle is used in extreme conditions (rain, dirt, long distances, etc.).

When conducting regular maintenance procedures make sure your bicycle is always clean and well protected by lubricants and cleaning agents. Ask your specialist dealer about appropriate lubricants and cleaning agents as well as information relating to their correct application.

⚠ WARNING

Risk of accident caused by a malfunctioning crank system due to loose screw connections.

-Check the required tightening torque of all screw connections after the first 100 km – re-tighten the connections if necessary. Repeat this check every 2500km! Apply fresh thread lock if necessary.

Risk of accident caused by a malfunctioning crank due to wear.

-Do not continue to use your Clavicula component if the Clavicula lettering is abraded at one or more points (wear indicator).

Risk of accident caused by malfunctioning brakes.

-After conducting any cleaning, maintenance or repair work make sure that the braking rims of your wheels are free from lubricants (such as grease, oil, silicon, Teflon, wax or other similar agents).

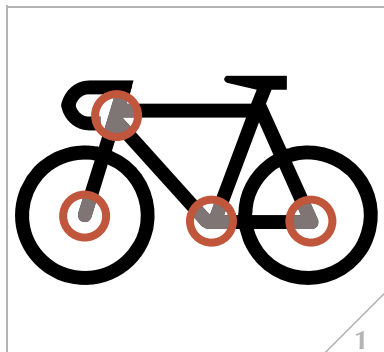

NOTICE

Never use a high-pressure cleaner or steam cleaner to clean your bicycle, as the seals of your bicycle components are unable to withstand the pressure. This will result in corrosion and material damage.

If you are using a hose, handle it with care - never aim the hose directly at the bearing components (fig. 1).

- ☞ Clean your THM-components at regular intervals by using water and a non-abrasive, environmentally-friendly cleaning agent.
- ☞ When cleaning your THM components always check for signs of damage (dents, cracks, scratches, large abrasions, worn areas, etc.).
- ☞ Periodically preserve the surface of your THM components using a high quality protecting wax or other similar agent.

Dismantling the bottom bracket

BB30/PressFit 30



When dealing with BB30, PressFit 30 and BBright™ PressFit bottom brackets the bearing cup with internal thread (1) or (3) is always located to the right, while the bearing cup with external thread (2) or (4) is always located to the left.

(fig. 2, 3)

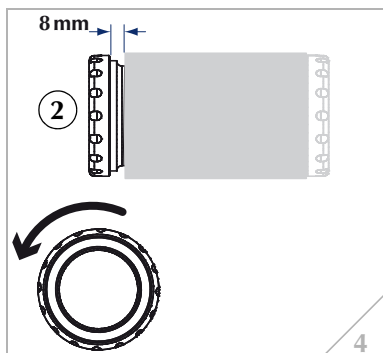
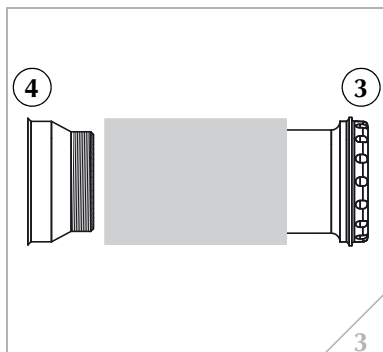
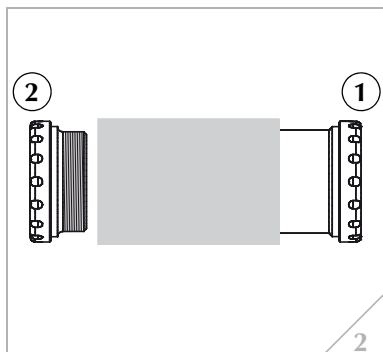

- Loosen the bearing cup (2) or (3) using an **anti-clockwise rotation** until there is a gap of approx. 8 mm between the bearing cup and bottom bracket housing.

(fig. 4, 5)

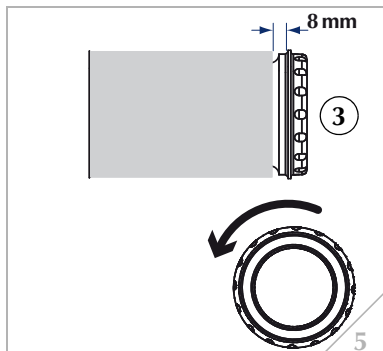

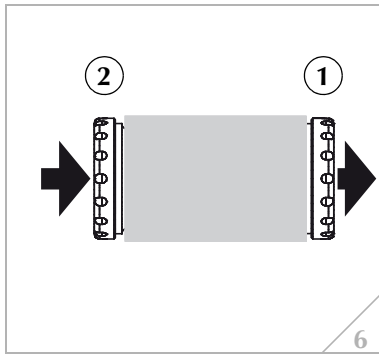

☞ Use a rubber mallet to carefully tap the bearing cup (2) or (3) until the bearing cup (1) or (4) is freed from the bottom bracket housing. (fig. 6, 7)

☞ Now twist the bearing cups apart by hand and remove these from the bottom bracket housing.

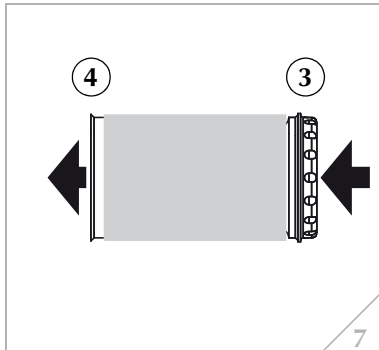

Press-fit/EVO386/BBright™ Direct Fit



Remove the Press-fit / EVO386 / BBright™ Direct Fit bottom bracket by using a suitable extraction tool (e.g. Shimano® TL-BB13).



Please contact us **before** returning a defective THM product!

If products are returned without our previous agreement, the shipping costs incurred will be charged to your account and, furthermore, we also reserve the right to refuse acceptance of the product.

When returning a defective THM product to us please ensure adequate postage costs are provided. Any shipment which is not prepaid will be rejected and returned to the sender!

Liability for defects

We provide a warranty for all THM products which covers material and processing defects.

We will replace defective products at no cost to the user within this period.

The liability period starts at the time the relevant THM product was purchased.

Liability does not extend to any kind of damage caused by normal wear and tear, accidents, unauthorised modifications, negligence or improper handling and use.

Liability shall expire if repair work or any other work on the THM product has been conducted by unauthorised persons.

The same shall also apply to any direct or indirect damage resulting from an action described in the preceding sentence.

Fair deal promise

Minor damage to your THM products will be repaired by our workshop free of charge even after expiration of the legal liability period, provided that the work required does not exceed 0.5 hrs.

The decision regarding whether or not a repair is to be carried out free of charge rests solely with us. If the damage has been self-inflicted, there is no entitlement to free repair work!

In the event of self-inflicted damage please send us the product concerned for inspection. After we have assessed the overhead for the required repair, we will either perform the repair free of charge, or we will send you a cost estimated. It is then up to you to decide whether or not to go ahead with the repair work.

Crash Replacement

In the event of irreparable damage (e.g. caused by accident) we will provide a 40% discount from the respective list price if you purchase a new THM product as a replacement. The relevant claim must be forwarded directly to THM Faserverbund-Technologie GmbH. The irreparable product shall then remain our property.

The company THM Faserverbund-Technologie GmbH is constantly striving to improve product designs as technical developments continue. We therefore reserve the right to make alterations which must not correspond to the text and illustration contained in this manual, and without incurring obligation to alter any products previously delivered. Technical specifications, dimensions and weights are to be understood with the corresponding allowances.

Reproduction or translation of this publication, in whole or in part, is not permitted without the written consent of the company THM Faserverbund-Technologie GmbH. All rights under the provisions of the copyright act are reserved.

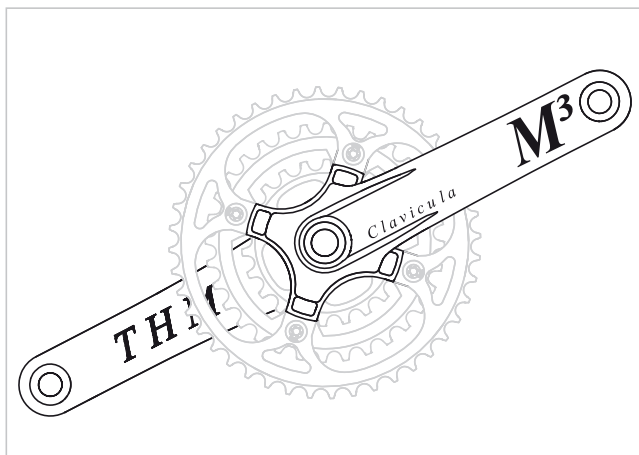

THM Faserverbund-Technologie GmbH
Am Sportplatz 3
D-24791 Alt Duvenstedt

 +49 4338 99 94-123

 +49 4338 99 94-122

info@thm-carbones.com

www.thm-carbones.com